

**ADHESIVE STICKER SPECIFICATIONS**

Europe	DVD, Blu-ray	EDS010	Issue 7	October 2022
--------	--------------	--------	---------	--------------

**General Requirements**

**General**

- Adhesive: May be peelable or permanent
- Supply: Reel format -- Sheet or other format is not acceptable
- Cutting: Excess material is to be stripped from backing web. The punching or die cutting **MUST** not cut into the backing web.
- Backing Web: To be continuous with no breaks or joins.
- Identification: **Each reel supplied** must carry a clearly readable label on the inner core, stating the quantity of stickers on reel and the unique catalogue/part/reference number by which the sticker is identified.  
**Each sticker on the reel** must contain the unique catalogue/part/reference number by which the sticker is identified.

**Materials:**

Label: Material White Label paper. Glossy Coated on one side  
 Grammage: 90gsm Test method ISO 536  
 Thickness: 77 microns Test method ISO534  
 Tensile strength: (Machine Direction of grain) approx.66 N/15mm Test method DIN53112

Release Liner: Honey Super calendared glassine  
 (Backing Web) Grammage: 60gsm Test method ISO 536  
 Thickness: 51 microns Test method ISO534  
 Tensile strength: (Machine Direction of grain) approx .80 N/15 mm Test method DIN53112

**Standard Shapes:** Simple geometric shapes like those shown below can be automatically applied onto a soft box.  
 Custom shaped labels will require manual application at an additional charge.



**Reel Size:** To machine apply stickers they must be supplied on reels  
 Core size 76mm, Reel diameter 280mm maximum

**NOTE:** For machine application, rolls of adhesive stickers can be up to 280mm diameter on a standard 76 mm core. Wherever possible, please supply **full rolls of maximum 280 mm diameter** and not multiple smaller roll sizes. This avoids time-consuming roll changes on the machine pack lines.

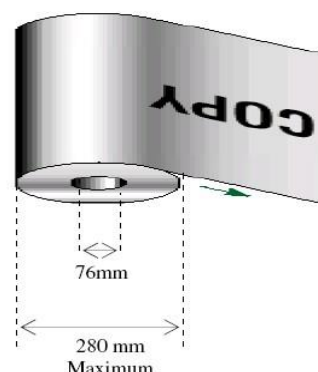

## Adhesive Sticker Specifications - Applied to DVD, HD and Blu-ray Inlay Wrap

The inlay wrap may have up to:

**2 stickers** applied to the printed outside face (see options A B and C below)

**1 sticker** applied to the underside of the inlay wrap before being assembled. (see option D) On the printed outside face of the inlay wrap there are **3 different size options** that may be applied:

**OPTION A:** - ONE sticker size 30mm x 22mm can be applied to FRONT of Inlay wrap only.

**Copy winding required:**

Copy 1

**Grid Positions:**

F1 to F15 inclusive  
as EDS 011 Specification

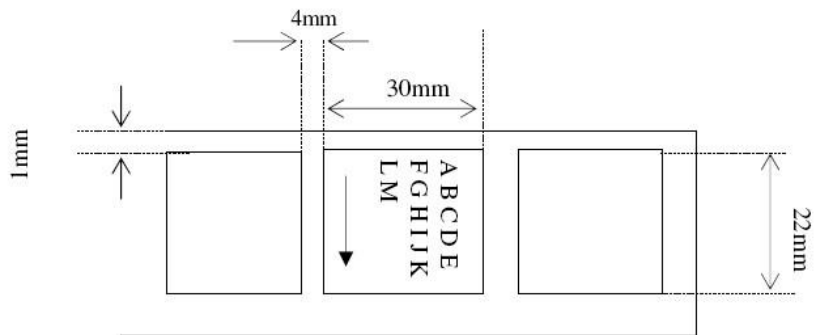

**OPTION B:** - ONE sticker size 11mm x 15mm can be applied to BACK or SPINE of Inlay wrap

**Copy winding required:**

Copy 1

**Grid Positions:**

Back: B1 to B15 inclusive  
Spine: S1 to S5 inclusive as  
EDS 011 Specification

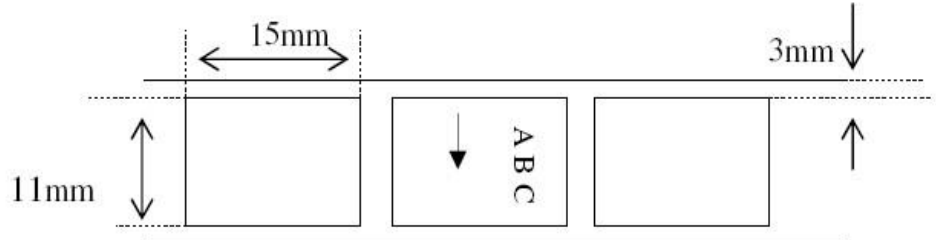

**OPTION C:** - ONE sticker size 15mm x 11mm can be applied to BACK or SPINE of Inlay wrap only.

**Copy winding required:**

Copy 1

**Grid Positions:**

Back: B1 to B15 inclusive  
Spine: S1 to S5 inclusive as  
EDS 011 Specification

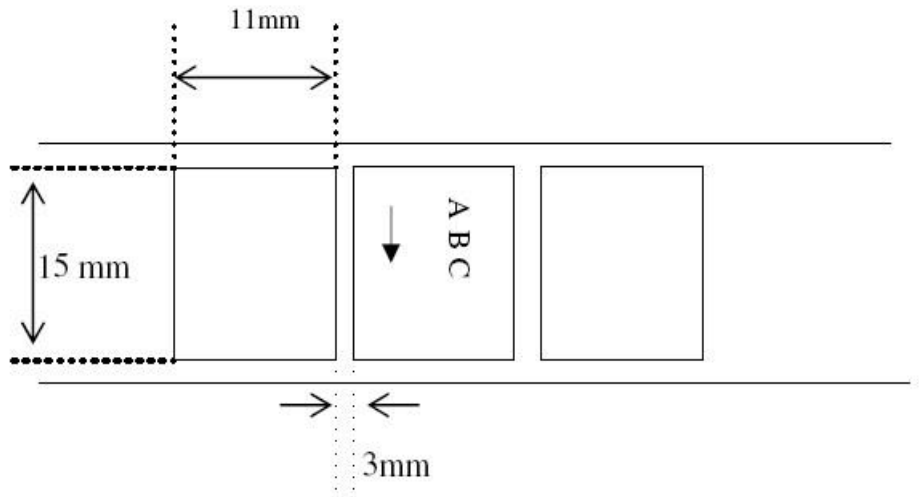

**OPTION D:** - ONE sticker size 15mm x 71mm can be applied on the **undecorated inside face of the inlay wrap** (only one option): -

**Copy winding required:** Copy 1

**Grid Positions:** IF1 through to IF15 inclusive as per IF15 as per EDS 011 Specification

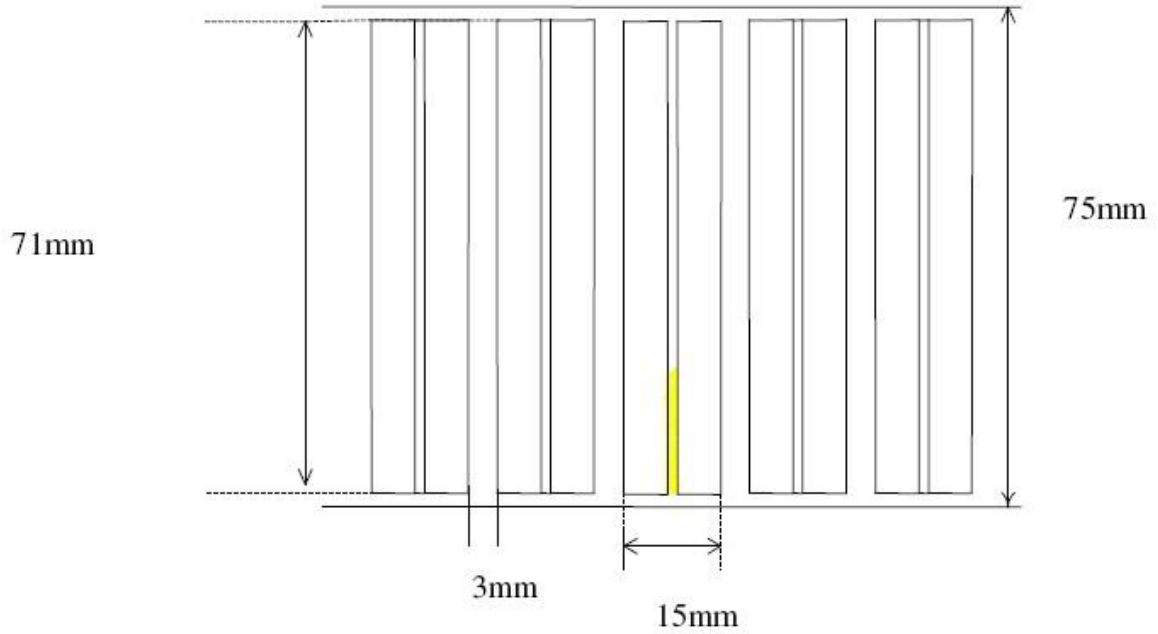

**Adhesive Sticker Specifications - Applied to DVD Soft box only**

**OPTION E:** - One Security label may be applied under the disc **INSIDE** the case.

These positions are **NOT** available for HD and Blu-ray- Please refer to Specification EDS 011 for security label application inside the case for a HD or Blu ray soft box

Copy winding required: Copy 1

Grid Positions: L1 through to L10 inclusive as below

Please see the diagram below to quote one chosen sticker reference when placing order:

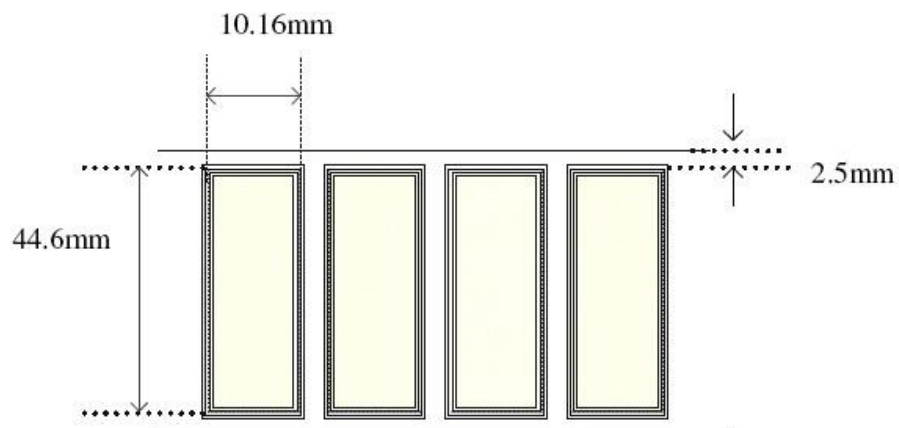
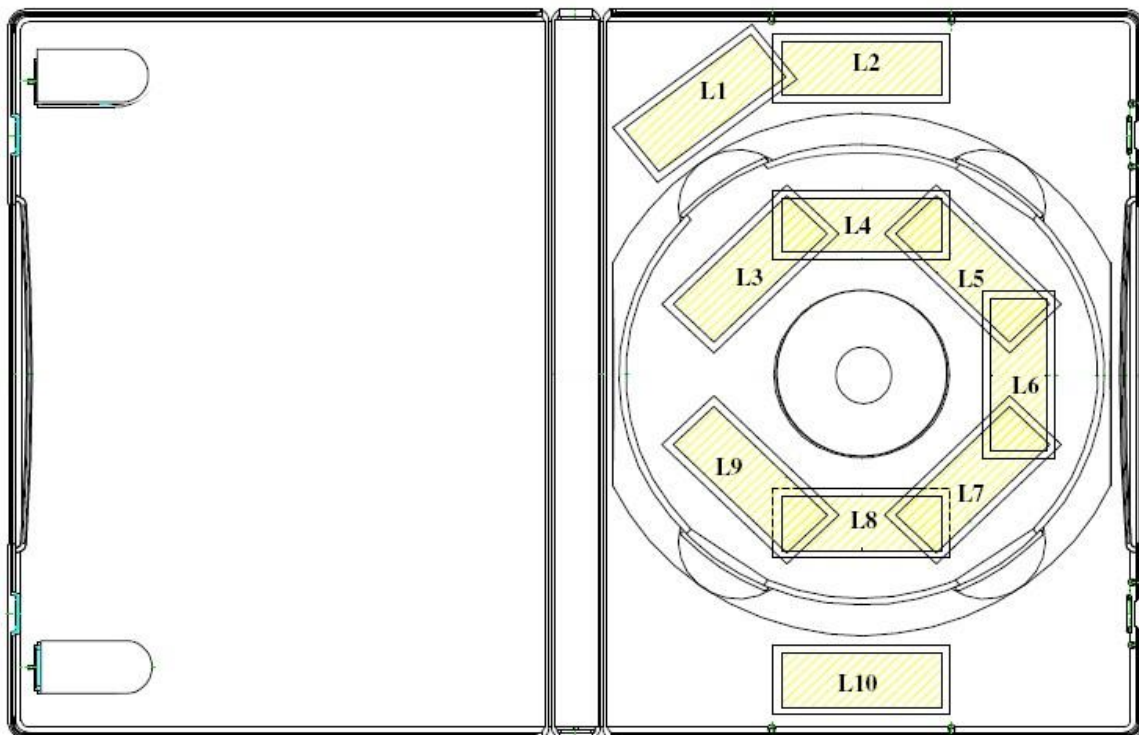

Sticker dimensions: 44.6mm x 10.16 mm

## **Adhesive Sticker Specifications - Applied to DVD, HD and Blu-ray Soft box**

**OPTION F:** - Up to 2 Stickers may be applied to the case **before** over wrapping the packed unit:

- One on the back and one on the front. (On case prior to Over wrapping)
- **Copy winding required:** Copy 4
- **Maximum sticker size:** 120mm wide x 140 mm height to fit the Soft box.

Please quote sticker position references as outlined in EDS011 - Sticker position references.

**OPTION G:** - Up to two stickers may also be applied to the case **after** over rapping the packed unit.

- One on the back and one on the front. (On top of over wrap)
- **Copy winding required:** Copy 4
- **Maximum sticker size:** 120mm wide x 140 mm height to fit the Soft box.

Please quote sticker position references as outlined in EDS011 - Sticker position references.

Adhesive Sticker Specifications - Sticker Windings

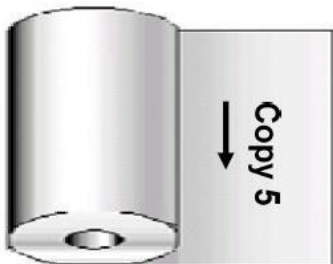
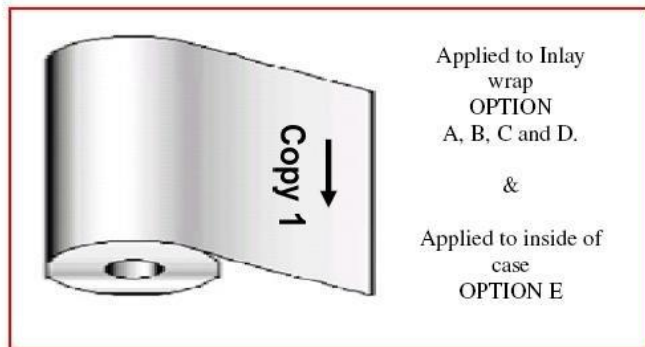
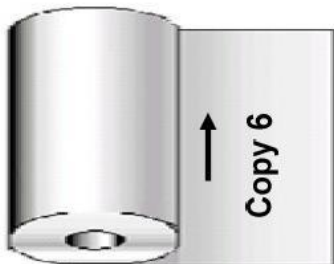
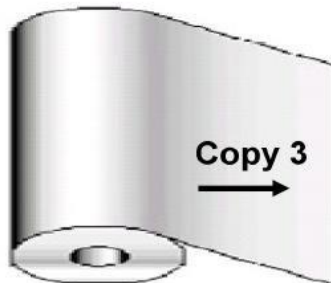
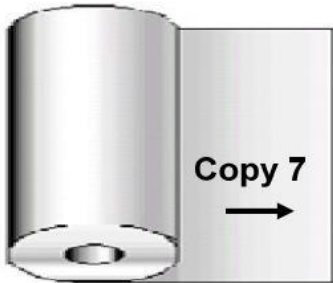
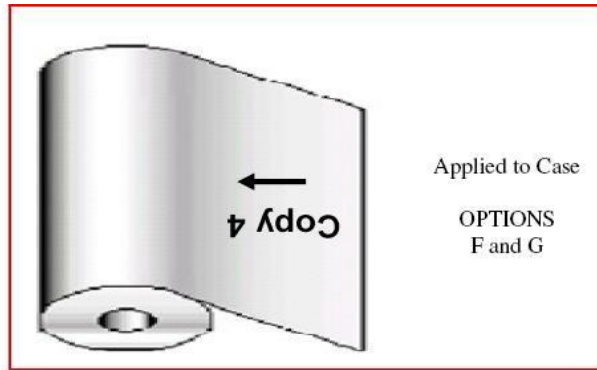
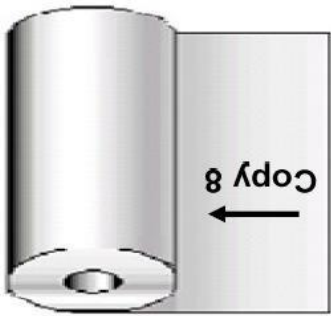

- Direction of text on sticker.
- Maximum sticker size: - 120mm x 140mm.
- Please see the sticker summary chart on next page for further clarification.

**Adhesive Sticker Specifications - Sticker Windings Summary Ref. Chart**

OPTION	Where Applied	Number of stickers of each sticker size and copy which can be machine applied on any single unit	Sticker Size	Winding required for automated application
A	On Outside of printed inlay wrap (Front face)	1	30 mm x 22 mm	Copy 1
B	On Outside of printed inlay wrap (Back or Spine )	1 <b>IF THIS OPTION IS CHOSEN YOU CANNOT ALSO SELECT OPTION C</b>	11mm x 15 mm	Copy 1
C	On Outside of printed inlay wrap (Back or Spine )	1 <b>IF THIS OPTION IS CHOSEN YOU CANNOT ALSO SELECT OPTION B</b>	15 mm x 11mm	Copy 1
D	On Inside of printed inlay wrap (Inside Front)	1	15mm x 71 mm	Copy 1
E	Inside <b>DVD</b> Soft box only underneath disc	1	44.6 mm x 10.16mm	Copy 1
F	On Soft box Before over wrapping packed unit.	2	Maximum Sticker size 120 mm x 140 mm	Copy 4
G	After over wrapping packed case, on actual over wrap	2	Maximum Sticker size 120 mm x 140 mm	Copy 4

**Note:** On the outside of a single printed inlay wrap you can machine apply 2 stickers, one on the inlay front and one on the back or spine area. Each sticker must be of a different size.