

Requirements for CD label print, input media, printed parts and stickers				
Europe	CD	EDS023	Issue 10	Oct 22

CD allowable print area specification

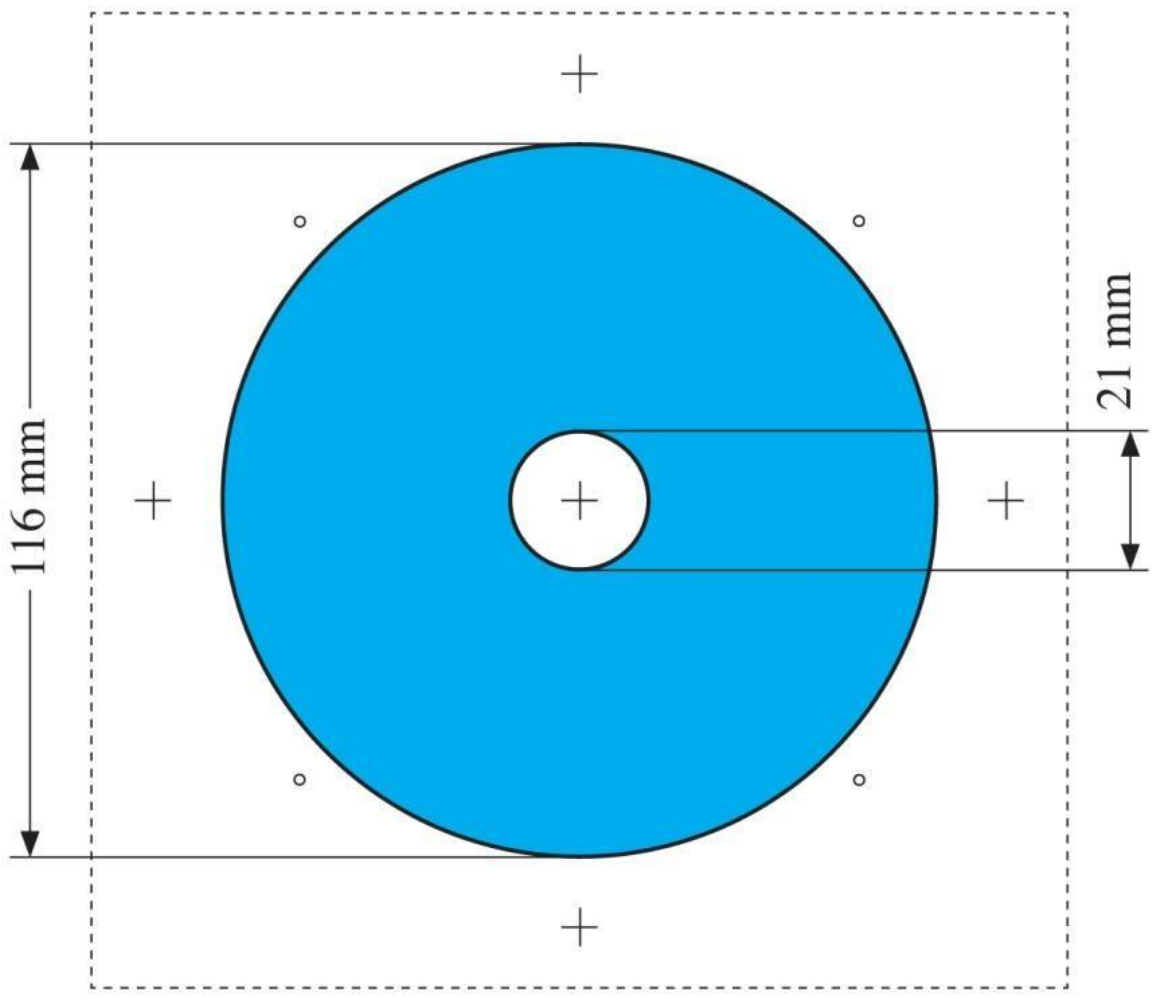

General notes:

The shaded area is the maximum allowable print area*

The catalogue or record number and the colour data must always be indicated at the edge of the film. We also recommend to include the catalogue or record number on the label film itself.

1-or 2-colour decorations without a white blackout

Please take into consideration, that metallization in matrix area ($\varnothing 45\text{mm}$) has different shade. All decoration elements placed in this area will have different background.

**Requirements for on-body label film**

Please check the DVD-specification “EDS003 Requirements for DVD On-Body Label Print” on Vantiva web-site.

Requirements for electronic artwork

Please check the DVD-specification “EDS002 Artwork Requirements” on Vantiva web-site.

Requirements for printed part film

Please check the DVD-specification “EDS007 Print Parts requirements” on Vantiva web-site.

Requirements for wallets

Please check the DVD-specification “EDS012 Requirements for wallets” on Vantiva web-site.

Requirements for standard booklets

Please check the DVD-specification “EDS014 Requirements for standard Jewel Box-Booklet” on Vantiva web-site.

Requirements for standard inlay card applied to jewel case

Please check the DVD-specification “EDS015 Requirements for Standard Jewel Box - Inlay Card” on Vantiva web-site.

Requirements for stickers applied on jewel case lids and wallets

Stickers - industry standard on winding and delivery instructions

An industry standard is in place on the windings of stickers, see reverse. Each winding has its own number which refers to a specific way the sticker is wound. Note: we only handle two types of windings. Please mark incoming boxes with the winding number and reel quantity. See details on reverse.

Normal usage

Stickers can be applied to the jewel case for identification or warning purposes.

Standard shapes

Simple geometric shapes, like those shown here, can be applied.

Odd-shaped stickers, or stickers made of translucent materials must be applied by hand and will be charged accordingly.

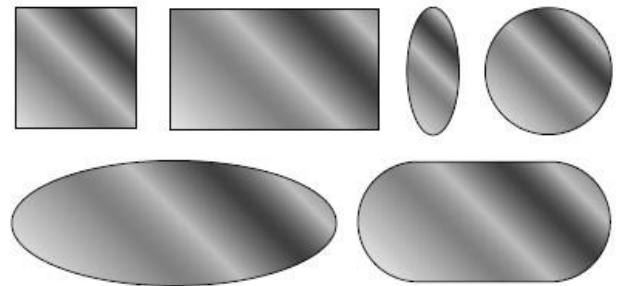

Sticker size

Width: 19 mm minimum to 100mm maximum

Height: 19 mm minimum to 100mm maximum

Roll size

Maximum overall diameter (X): 280mm max

Core internal diameter (Y): 76mm

General

- 1 Stickers are to be evenly spaced 3mm minimum or more, apart.
- 2 Stickers are to be die-cut with backing uncut and waste removed.
- 3 Only one sticker is allowed across the roll.
- 4 All stickers received in sheet format are handpack only.

Orientation

- A Stickers are to be orientated so that the right edge of the sticker comes off first for use on lids of CD jewel cases (see 3 overleaf).
- B Stickers are to be orientated so that the left edge of sticker comes off first for use on wallets, sleeves or the base of CD cases (see 4 overleaf).

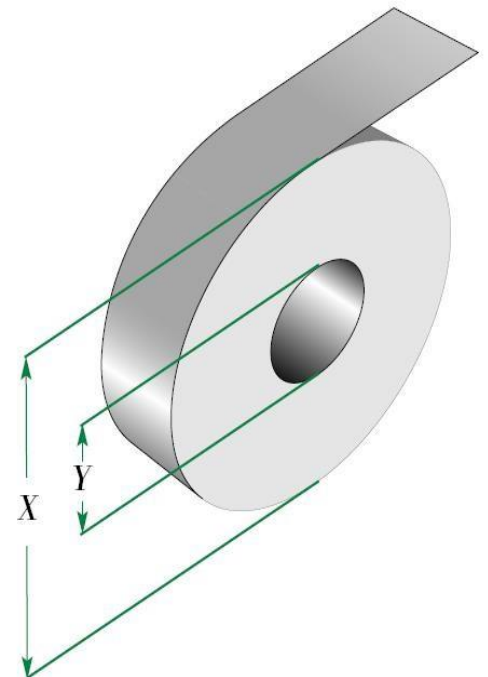

Requirements for stickers applied on jewel case lids and wallets

Winding copy 3

For stickers applied on jewel case lids only



Winding copy 4

For stickers applied on sleeves, wallets and the base of CD cases

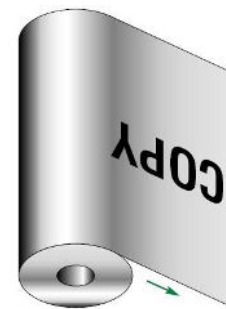

CD audio master media specification

Audio programme formats

Audio programs for CD mastering can be accepted in any of the following formats subject to limitations:

1 *Virus check*

In case of a virus detection when controlling your master CD-R, Vantiva will send you the artwork back and ask for a new one. Vantiva will not be held responsible for the manufacturing delay if the above mentioned problem occurs.

2 *CD (Production Copies)*

A production CD (conforming to Red Book Specification) submitted as the programme master will be copied exactly as it is. In many ways, this is the simplest input format, since it can be used with the minimum of delay.

3 *CD-R*

Since a CD-R is physically very different from a production CD and is highly vulnerable to handling it must be treated with the utmost care before being sealed in its box and shipped for mastering. Avoid writing on the disc over the recorded area, use the centre area for IDs.

CD-Rs should be prepared to Orange Book Specification. This limits subcode information to track starts only. If bar-code and ISR Codes are required we can encode them at the mastering stage. It should be noted that more sophisticated CD-R writer systems may give rise to unpredictable problems, in producing CD-Rs not strictly to orange Book Specification. Both single and multi-session CD-Rs are acceptable, but please provide the fullest details about the preparation of the CD-R, i.e. equipment and software used, single or multi-session, printout of playlist, plus any other relevant details. Without this information we may not be able to proceed.

4 *Timing Information*

With each master, whatever the format, we need to know the start and stop times of each track on the disc. This information is recorded with the music on the disc and enables the CD player to find the tracks quickly. As a licensee of the inventors of CDs (Philips/Sony), we are required to manufacture CDs that conform to their specifications known as the "Red Book". This was devised to ensure playability of all discs on all players. In order to comply with those specifications the maximum permissible playing time is 74 minutes (including pauses).

Longer playing times can be obtained by cutting at slower velocities and lower pitches but doing so compromises the specifications and may result in playability problems on some players/drives. Therefore we strongly advise all content owners to stay within this 74 minute limit. Longer programme lengths may be accepted providing a disclaimer is supplied with the order, absolving Vantiva Manufacturing from any responsibility with regard to playability problems that may be encountered.

Vantiva will not make any effort to manufacture CD's with playing time longer than 79 min 40 sec (including pauses).

It should be noted that the minimum track length permitted by the CD specification is 4 seconds.

A short identification code specified by the customer consisting of up to 24 capital letters, numbers or spaces, will be laser-engraved round the centre of the disc. This may simply be the catalogue

number, but in any case it must correspond to an identification code printed on the label, booklet and inlay card.

The list of characters which are not permitted: ` ~ ! @ # ^ & () _ = + [{] } \ | ; : ' " , < > ? Vantiva cannot accept liability for any errors in the finished CD resulting from an error in the Audio, Subcode or Paperwork information supplied by the customer.

It helps us to check the timings if the playlist includes lengths of tracks as well as start and stop times; the total length of the disc should also be given.

CD ROM input media and data specification

Guidelines for CD-ROM Data Transfer

Vantiva Information Systems is constantly upgrading the forms of media it can accept for CDROM transfer with an aim of staying at the forefront of CD-ROM manufacturing technology. With so many different archive media available the task of supporting all of them is an endless one. Here at Vantiva we take pride in our ability to meet all your needs and we are always ready to advise on any data transfer problems. Currently we accept the methods listed below and are always ready to introduce new software and hardware to enable us to accept your data. The mentioned formats are acceptable means of supplying an image or indeed raw files for formatting to specific standards

1 *Virus check*

In case of a virus detection when controlling your master CD-R, Vantiva will send you the artwork back and ask for a new one. Vantiva will not be held responsible for the manufacturing delay if the above mentioned problem occurs.

2 *CD-R*

The Compact Disc Recordable, has become the most preferred transfer medium. The discs must conform to the "Orange Book" standard. Vantiva can accept CD-ROM, CD-XA, CD-I, mixed mode, CD Extra, ROM-Ready and "Red Book" Audio discs as input for mastering.

When supplying a multi-session disc please ensure that any ROM tracks are in XA format, the disc has been properly finalized and contains a valid TOC. Vantiva will, by default, clone all sessions. Vantiva will also, by default, conditionally increase the postgap to 2 seconds. This is to ensure conformity to specifications as many submitted CD-R's contain insufficient or no postgap. It is therefore the customer's responsibility to report any protection method, on the data master, that relies upon specific track times, beginning to lead-out, etc., prior to submission for mastering.

Also, due to the nature of the medium itself, it is preferred that the customer should supply a branded make of CD-R, in good condition with no apparent marks on the recorded side. It should come in a separate, plastic "jewel-case" type box, 1 CD-R per mastering required.

3 *Compact Discs*

Compact discs are an excellent way to send data and audio. ISO 9660, is acceptable with accompanying instructions for alteration to the disc structure. ISO 9660 is an international standard originally devised for storing data on CD-ROM.

4 *Supplying a Disc Image*

If you want to supply Vantiva with data already formatted into CD sectors, we can accept the following formats:

- MODE 1
- MODE 2 (Form 1 or 2)
- CD-I
- CD-I Ready
- CD-XA
- CD-DA

Enhanced CD

When supplying Vantiva with a complete disc image specify the total block count and what software was used to process it. The preferred transfer media for a complete disc image is a CD-R disc. Most compact disc formatting software available today supports these formats.